

# Basic Installation Instructions for the Sleeveless Bevel-Sert (Ductile Iron Pipe Application)

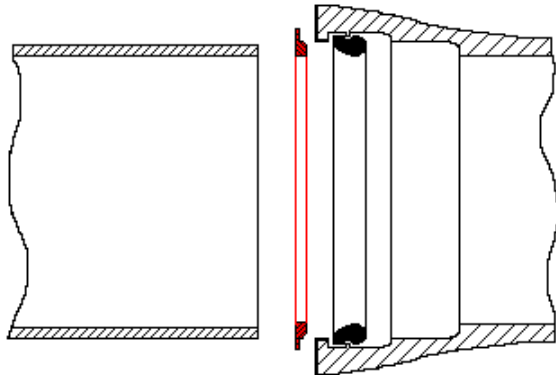

Insert the rubber gasket into the bell end of the pipe or fitting, following pipe manufacturers' recommended practices

Lubricate rubber gasket adequately, using NSF approved lubricants only. The use of spray lubricants is not recommended.



4" through 12" dia.

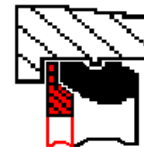

14" through 48" dia.

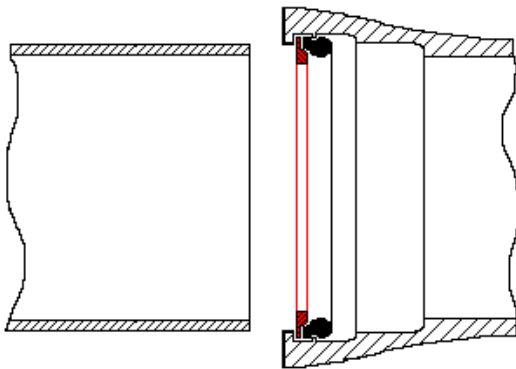

Insert the "Bevel-Sert" into the bell end of the pipe or fitting, seating it in front of the lubricated rubber gasket. Make sure the flanged portion of the Bevel-Sert is behind the inside portion of the bell end.

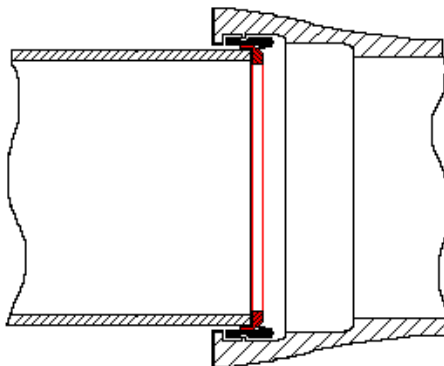

Push the spigot or "male" end of the pipe into the bell end, using minimal deflection and constant, steady forward pressure.

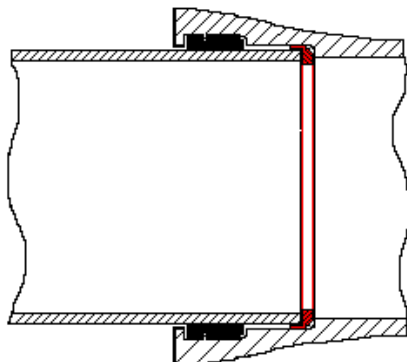

Press spigot or "male" end into bell end until the pipe is seated in its "home" position". Deflection may be used at this time, following pipe manufacturers' recommendations.